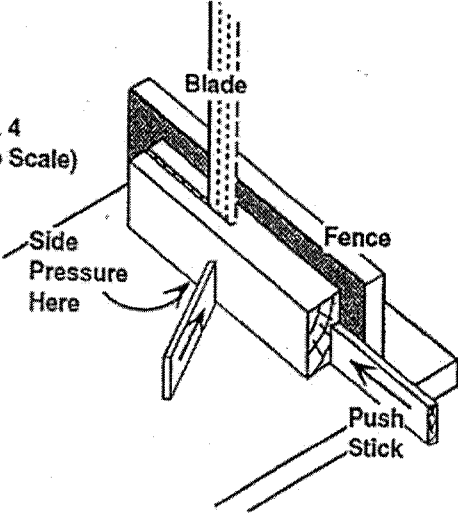

Skill Activity 2

RIPPING AND RE-SAWING

Completed ✓	Procedure
<input type="checkbox"/> <input type="checkbox"/> <input type="checkbox"/> <input type="checkbox"/> <input type="checkbox"/>	<ol style="list-style-type: none">1. Review the Band Saw safety rules.2. Obtain 2 pieces of $\frac{3}{4}$" x 3" x 15-1/2" stock.3. Lay out a straight line along one edge half the thickness of the stock. Using a pivot block, lower the blade guide to the proper position, and resaw the stock on the line.4. Use one of the cut pieces to test for and align a straight fence for drift.5. Place the fence in position, either inside or outside the blade, and resaw piece B exactly in half. Use a push stick to feed the work through the saw. Hold the stock against the fence with a support block. <p>-----</p> <p data-bbox="461 1121 813 1157">Resawing on The Bandsaw</p>  <p data-bbox="841 1052 992 1115">Fig. 4 (Not to Scale)</p> <p data-bbox="1094 1010 1159 1037">Blade</p> <p data-bbox="1240 1163 1305 1190">Fence</p> <p data-bbox="938 1163 1040 1247">Side Pressure Here</p> <p data-bbox="1256 1346 1321 1394">Push Stick</p>