

Skill Activity 1

PARTS AND ADJUSTMENTS FOR A TABLE SAW

Completed	Procedure
□	1. While standing at the machine, use the labeled drawing, manual and textbook to locate the following: switch, sawblade, arbor, blade height adjustment handwheel and lock, blade tilt adjustment handwheel and lock, fence, fence clamp, miter gage, splitter, guard, tilt scale, table insert.
□	2. Unlock the height adjustment. Raise the saw blade to project 2" above the table. Lower it to 1/2" projection. Raise to 3". If movement is difficult - see instructor.
□	3. Unlock the tilt adjustment. Tilt the blade to 27 1/2 degrees as shown on the tilt scale. Return it to 0 degrees and check the setting with a try square or plastic triangle.
□	4. Set the fence to cut 5" width. Test the fence accuracy with the saw locked out. <u>Ask for assistance if you are unsure how to lock the saw out.</u> Note: Always measure from the point of a tooth that is pointing toward the work piece and away from the cut-off or scrape. See sketch.

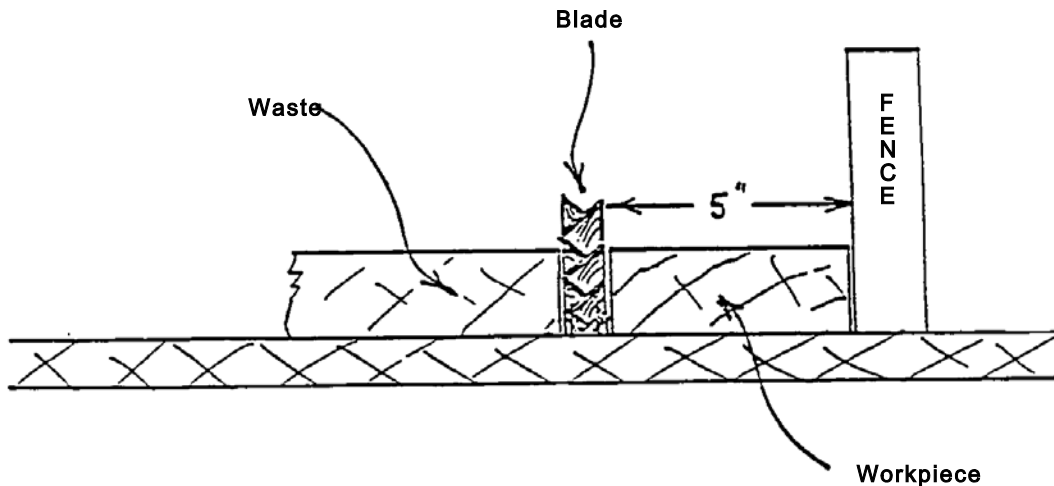

Completed

Procedure

- 5. Set the fence to cut $2\frac{1}{4}$ " width. Check to see if the fence is parallel by measuring from teeth at the front and rear of the blade. The measurements should be equal. Check with instructor if the fence is not parallel. See sketch.

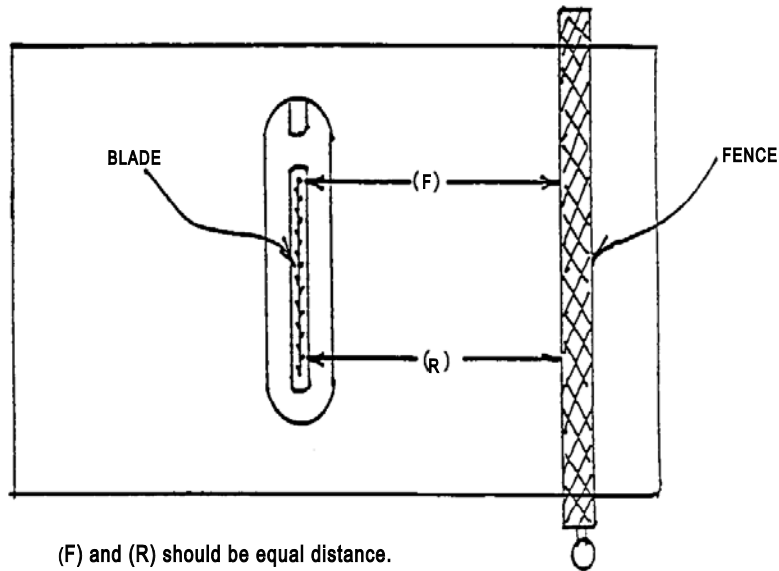

- 6. Set the miter gage to cut a 45 degree miter. Return it to the 0 degree setting and check it against the blade with a try square.
- 7. Practice removing and replacing the splitter. When not in use, the splitter should hang from the hooks on the blade guard arm along with the push sticks.
- 8. Locate the standard and Zero-clearance throat plates; Practice removing and reinstalling
- 9. Inform instructor if any parts are not free-moving or appear damaged.