

Information Sheet 3

TEMPLATE AND PATTERN ROUTING

Free hand routing is seldom an option because of the inability to control the router. When non-linear routs are desired, the solution typically requires fabricating a template and using a Template Guide or a Pattern Bit. Each approach offers advantages and disadvantages.

GUIDE BUSHINGS. Guide bushings attach to the bottom of your router base. They come in various diameters and lengths. They are used in combination with a straight bit, which must be slight smaller than the inside diameter of the Guide bushing. Guide bushings are great for plunge cuts or routing a groove for inlays. The only issue is that there is always an offset between the edge of the bushing and the bit. That means you'll need to calculate this offset so that your piece will end up the correct size (drawing, below).

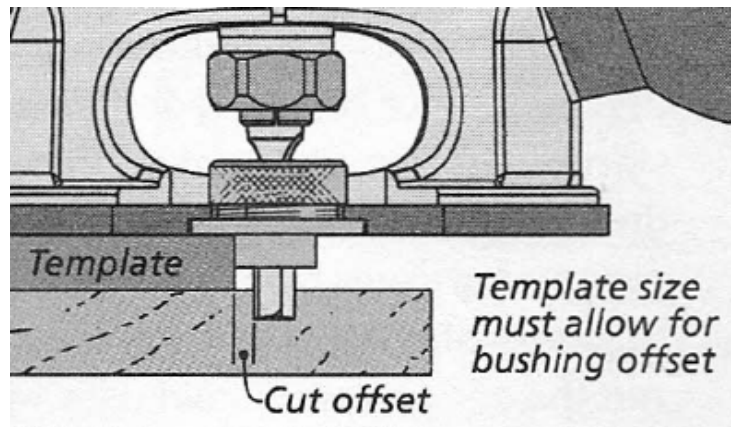

PATTERN BITS. The other option is a Pattern bit. It's like a flush-trim bit except that the bearing is right above the cutting edges. This allows you to use a hand-held router with the template attached to the top of the work piece. The one drawback to a pattern bit is that the cutting edges of the bit extend down past the work piece (drawing, below right). This means you need to clamp the work piece so it overhangs the edge of your work surface to prevent damage, and you cannot plunge with a Pattern bit. This bits come in various lengths, which allows for shallow grooves to be cut.

